

# The Equivalence of Various Methods of Computing Biquad Coefficients for Audio Parametric Equalizers

Robert Bristow-Johnson  
*Wave Mechanics, Inc., Burlington VT*  
robert@wavemechanics.com

**ABSTRACT:** Several authors have put forth design procedures for obtaining the coefficient values for second order digital filters to be used as parametric equalizers or "presence" filters. Given the EQ parameters, these differing design methods, having greatly disparate degrees of complexity, compute the filter coefficients. This paper shows that, with the possible exception of Q or bandwidth definition, all methods must be equivalent and the simplest method may be used. A method of computation is presented here in which the bandwidth is specified in octaves.

## 0 INTRODUCTION

Applying a second order IIR filter to the problem of parametric equalization appears to be so natural and straightforward that one might expect the design solution to have been worked out, published, and universally accepted long ago. However, this does not seem to be the case.

A few different second order IIR filter topologies have been suggested for use for the parametric equalizer or "presence" filter. These include the Direct Form I (or Direct Form II) (McNally [1], Moorer[2], White [3], Mitra, et.al. [4]) and Allpass (usually using the Lattice or Normalized Ladder forms) with feedforward (harris & Brooking [5], Regalia & Mitra [6], Massie [7]). Although they have differing round-off noise, limit cycle, and saturation characteristics, all can be simplified to have the same form of transfer function as the Direct Form I filter having 5 independent coefficients. This means that any scheme for computing coefficients (given the input parameters: boost/cut frequency, boost/cut gain, and Q or bandwidth) for one form can be compared to and adapted to another form if desired. This means, specifically, that the scheme used in Moorer's "*Manifold Joys...*" paper [2] (for 5 coefficient Direct Form I) can be used in the Normalized Ladder instead of the method proposed by Massie/Mitra. Or vice versa. Moorer's method is much more complex than the methods proposed by Massie, Mitra, or White but seems to deal with the definition and implementation of the EQ bandwidth more satisfactorily than the latter papers.

This paper compares the different methods, the claims made therein, and the input parameter definitions assumed. While the emphasis is on determining the standard biquadratic transfer function coefficients from which the Direct Forms I or II derives its coefficients directly, some

attention will be given to the nearly trivial problem of converting to the coefficients in the Lattice or Normalized Ladder forms in case that may be the desired implementation.

## 1 FOUR EQUATIONS, FIVE UNKNOWNNS

The five coefficient biquadratic discrete-time filter shown in the Direct Form I in Fig. 1 has the transfer function shown below.

$$H(z) = \frac{b_0 + b_1z^{-1} + b_2z^{-2}}{1 + a_1z^{-1} + a_2z^{-2}} \quad (1)$$

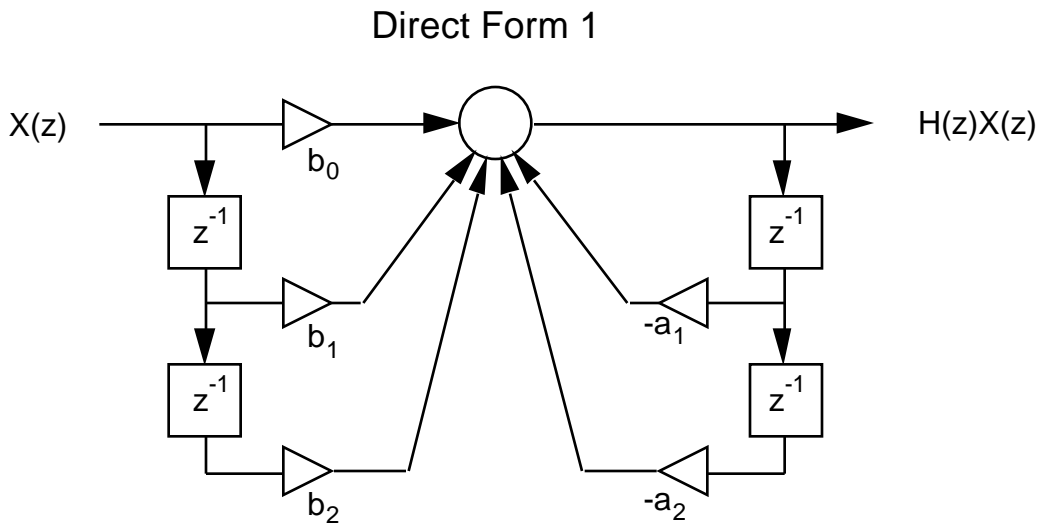

Figure 1

If the filter is designed to be a parametric equalizer (or “presence” filter) boosting (or cutting) the gain for a given frequency, the magnitude frequency response may appear as one of the plots in Fig. 2. Immediately, there are four requirements, expressed as four equations that can be postulated:

The magnitude gain at DC and at the Nyquist frequency must be zero dB.

$$H(e^{j0}) = H(1) = 1 \quad (2)$$

$$H(e^{j\pi}) = H(-1) = 1 \quad (3)$$

At some specified frequency,  $\omega_0$ , the gain must peak or notch, that is

$$\text{---} |H(e^{j\omega})|_{\omega=\omega_0} = 0$$

or

$$\text{---} |H(e^{j\omega})|_{\omega=\omega_0}^2 = 0. \tag{4}$$

At that frequency,  $\omega_0$ , the gain is  $G$  dB.

$$|H(e^{j\omega_0})| = 10^{\frac{G}{20}} K \tag{5}$$

Here we have four constraints, eqs. (2) - (5), and five coefficients to determine,  $H(z)$ , resulting in many possible solutions as shown in Fig. 2. The obvious difference between these solutions is the  $Q$  or bandwidth of the boost (or cut) region and if that bandwidth is defined and constrained, there is exactly one set of five coefficients that will satisfy all five constraints.

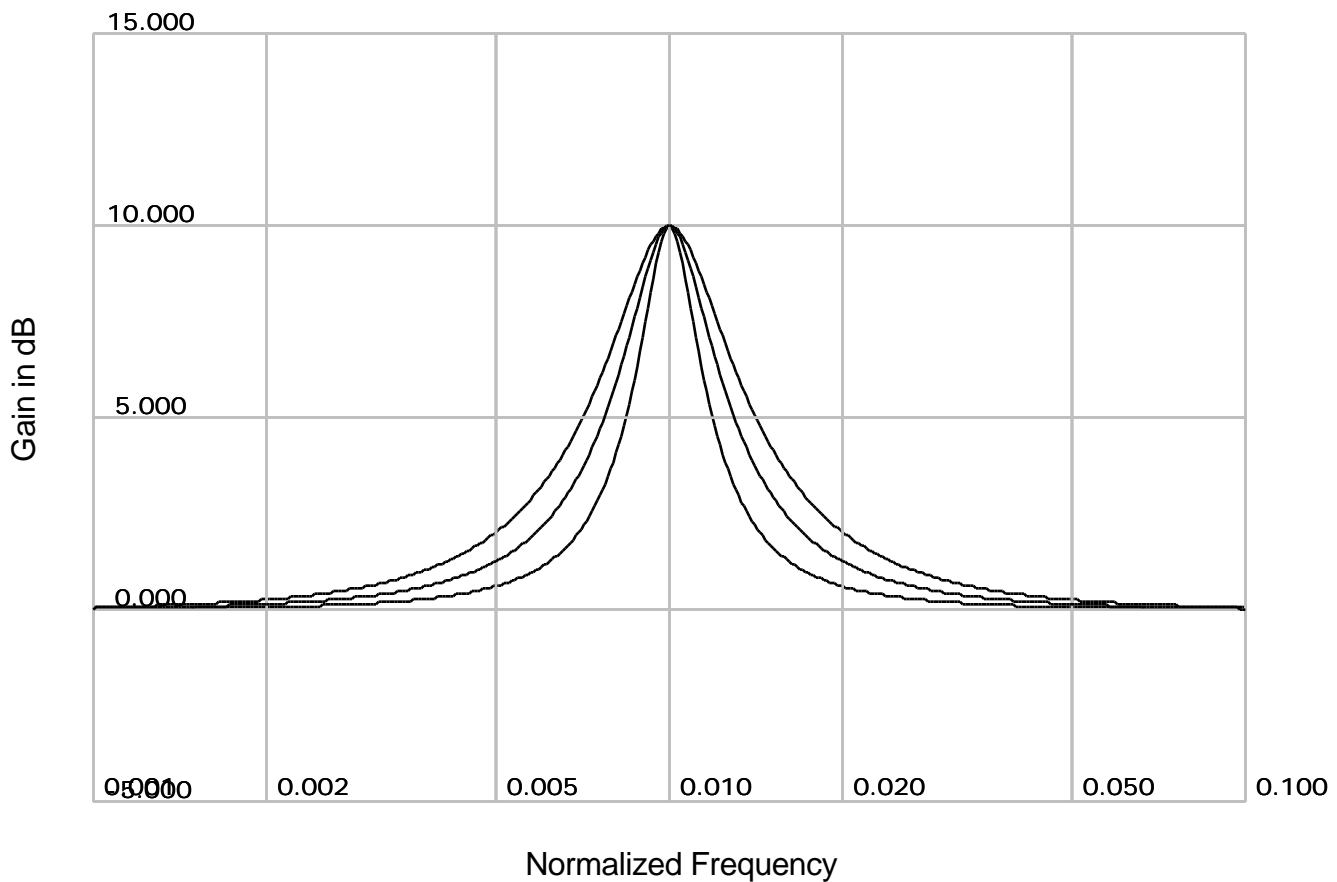

Figure 2

## 2 BANDWIDTH RE-REVISITED

The problem that the author has observed in the literature is that there is little agreement or consistent definition in equalizer bandwidth. However, since everyone agrees on four of the five constraints, the only resulting difference, on frequency response, of the design procedures put forth can be in bandwidth. In addition, if everyone can agree on bandwidth definition, all design methods **must** result in the same five coefficients, regardless of their complexity or elegance.

Regalia & Mitra [6] (and consequently Massie [7]) define bandwidth to be the frequency difference between the -3 dB points for a notch filter of - dB notch gain. For other gains, the distance from zero of the pole pair remains unchanged for constant bandwidth. No other claim regarding bandwidth is made for arbitrary boost/cut gains. harris & Brooking [5] seem to have the same bandwidth definition. One problem with this definition is that complementary equalizers with the same defined bandwidth, boost/cut frequency, and opposite boost/cut gains, do not cancel each other to result in a flat 0 dB overall response.

White [3] defines the bandwidth to be the frequency difference between the -3 dB points for any cut and the +3 dB points for any gain. Of course, no bandwidth can be defined for boosts or cuts of less than 3 dB and the design procedure breaks down in those cases.

Moorer [2] deals with the bandwidth issue much more satisfactorily by defining bandwidth to be the frequency difference between the two bandedges on either side of the boost/cut frequency that has any specified gain between 0 dB and the boost/cut gain,  $G$ . He goes on to suggest a bandedge gain of 3 dB below/above the peak/notch for a boost/cut over 6 dB. For a boost/cut gain of less than 6 dB, he suggests defining the bandedge at the midpoint gain ( $G/2$  dB) from 0 dB to the boost/cut gain.

This “midpoint dB gain” definition for bandedge gain is attractive because it is mathematically consistent and simplifies the design. Like the bandwidth definitions of White and Moorer, a cut of  $N$  dB exactly cancels a boost of  $N$  dB for any given  $N$ , boost/cut frequency, and bandwidth. An additional feature is that a boost (or cut) of  $N$  dB cascaded with another boost (or cut) of  $M$  dB very nearly approximates the frequency response of a single second order equalizer having a boost (or cut) of  $N+M$  dB, all filters having the same boost/cut frequency and bandwidth. This is because the magnitude frequency response for both cases agree exactly at five frequencies: DC, Nyquist, peak/notch, and the two bandedges. Although it may be subjective, this seems to make the performance of the equalizers more predictable to the user.

Another issue regarding equalizer bandwidth that seems to be missing in the literature but not in practice, is that if the equalizer is to be used in the studio (as opposed to a lab), the upper and lower bandedges should be related to each other in terms of octaves, not frequency difference.

### 3 DETERMINING THE EQUALIZER TRANSFER FUNCTION

Presented here is one more twist at this parametric equalizer design problem. It would be re-inventing the wheel except that here the bandwidth is specified in octaves. It uses the most straightforward approach similar to that used by White [3]. The approach used here is designing a continuous-time (analog) prototype, mapping to a discrete-time filter using the bilinear transform, and fixing the effects of frequency warping caused by the bilinear transform.

We start with the analog prototype filter:

$$\hat{H}(s) = \frac{s^2 + 2K_0 s + \omega_0^2}{s^2 + 2\omega_0 s + \omega_0^2} \quad (6)$$

It can be easily be shown that

$$\hat{H}(j0) = \hat{H}(j\infty) = 1, \quad \hat{H}(j\omega_0) = K, \quad \text{and} \quad \left. \frac{d}{ds} |\hat{H}(j\omega)|^2 \right|_{\omega=\omega_0} = 0.$$

The four equations above, after bilinear transformation, satisfy the initial four conditions expressed in eqs. (2) - (5) if the analog peak/notch frequency,  $\omega_0$ , is “pre-warped” and set to be

$$\omega_0 = \frac{2}{T} \tan \frac{\omega_0 T}{2} \quad \text{where} \quad \frac{1}{T} = \text{sampling frequency}. \quad (7)$$

The only variable left to solve for is  $K$  which is determined by satisfying the bandwidth specification. At the bandedge frequencies, the gain is  $G/2$  dB.

$$|\hat{H}(j\omega)| = 10^{\frac{G/2}{20\text{dB}}} = \sqrt{K} \quad \text{or} \quad |\hat{H}(j\omega)|^2 = K$$

This results in

$$K = \left[ 1 + 2K_0^2 \pm 2\omega_0 \sqrt{K_0(K_0^2 + 1)} \right].$$

The upper bandedge frequency (squared) is

$$\omega_+^2 = \omega_0^2 \left[ 1 + 2K^2 + 2\sqrt{K(K^2 + 1)} \right] \quad (8)$$

and the lower bandedge is

$$\omega_-^2 = \omega_0^2 \left[ 1 + 2K^2 - 2\sqrt{K(K^2 + 1)} \right]. \quad (9)$$

Relating the bandedge frequencies by the bandwidth,  $bw$ , defined in octaves,

$$\omega_+ = \omega_- 2^{bw} = \omega_- e^{\ln(2)bw}.$$

$$\omega_+^2 e^{-2bw} = \omega_-^2 \quad (10)$$

Combining eqs. (8)-(10) results in

$$\omega_-^2 = \frac{1}{K} \left[ -1 \pm \sqrt{1 + \frac{1}{4}(e^{2bw} - e^{-2bw})^2} \right]$$

Since  $\omega_-^2$  must be positive, we chuck the minus sign resulting, after further simplification, in

$$\omega_-^2 = \frac{1}{\sqrt{K}} \sinh \frac{\ln(2)bw}{2} = \frac{1}{\sqrt{K}} \sinh \frac{\ln(2)bw}{2} \omega_0^2.$$

The analog filter is completely designed, resulting in

$$\hat{H}(s) = \frac{s^2 + 2\sqrt{K} \sinh \frac{\ln(2)bw}{2} \omega_0^2}{s^2 + \frac{2}{\sqrt{K}} \sinh \frac{\ln(2)bw}{2} \omega_0^2}. \quad (11)$$

To design the digital filter, the bilinear transform is used which substitutes

$$s = \frac{2}{T} \frac{1 - z^{-1}}{1 + z^{-1}} \quad H(z) = \hat{H}(s) \Big|_s = \frac{2}{T} \frac{1 - z^{-1}}{1 + z^{-1}}$$

resulting after some simplification in

$$H(z) = \frac{1 + \frac{T}{2} s + 2K}{1 + \frac{T}{2} s + 2} \frac{1 - \frac{T}{2} s}{1 - \frac{T}{2} s} z^{-1} + \frac{1 + \frac{T}{2} s - 2K}{1 + \frac{T}{2} s - 2} \frac{1 - \frac{T}{2} s}{1 - \frac{T}{2} s} z^{-2}. \quad (12)$$

Because

$$s = j\omega = \frac{2}{T} \frac{1 - z^{-1}}{1 + z^{-1}} = \frac{2}{T} \frac{z - 1}{z + 1} = \frac{2}{T} \frac{e^{j\omega T} - 1}{e^{j\omega T} + 1} = j \frac{2}{T} \tan \frac{\omega T}{2} \quad (13)$$

results in frequency warping, moving the digital peak/notch frequency,  $\omega_d$ , to  $2 \arctan \frac{\omega_a T}{2}$ , the analog peak/notch frequency must be pre-compensated as in eq. (7).

This would complete the design except that frequency warping also affects the bandedge frequencies, causing the bandwidth to shrink as the peak/notch frequency is increased. This is illustrated in Fig. 3

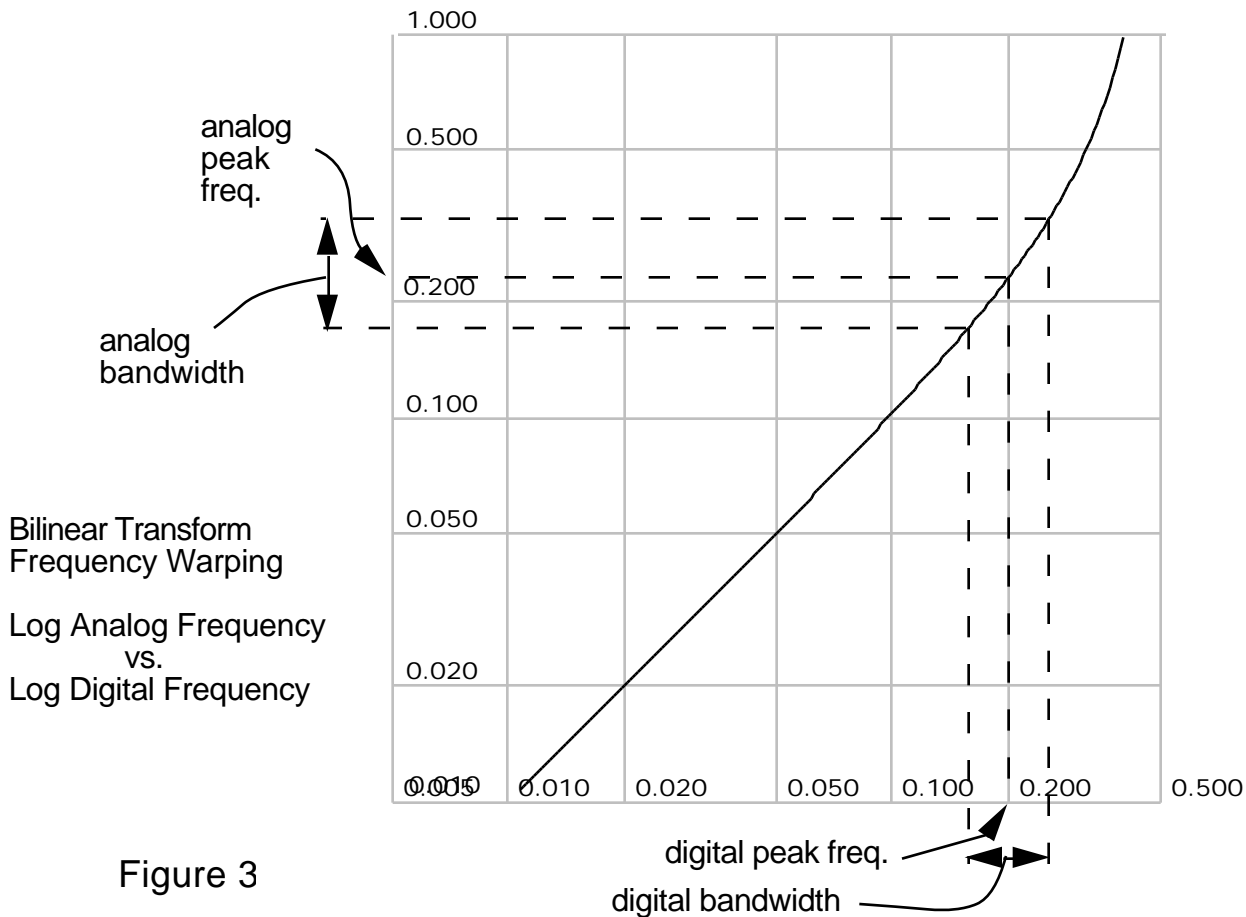

Figure 3

To fix this exactly, the following equation along with eqs. (7)-(9) would have to be solved for  $\omega$ .

$$\arctan \frac{-T}{2} 2^{bw} = \arctan \frac{+T}{2}$$

This does not lend itself to a closed form solution. An inexact but quite accurate alternative is to pre-compensate the bandwidth. Differentiating log analog frequency with log digital frequency in eq. (7) around the vicinity of the peak/notch frequency results in

$$\begin{aligned} &= \frac{2}{T} \tan \frac{\omega}{2} \\ \ln(\omega) &= \ln \frac{2}{T} + \ln \tan \frac{e^{\ln(\omega)}}{2} \\ \frac{(\ln(\omega))}{\ln(\omega)} &= \frac{1}{\sin(\omega)} \\ bw &= \frac{0}{\sin(\omega)} bw \end{aligned} \tag{14}$$

Using eqs. (7) and (14) to prescale the analog peak/notch frequency and bandwidth and adjusting eq. (12) finally results in

$$H(z) = \frac{(1 + \sqrt{K}) - 2\cos(\omega_0)z^{-1} + (1 - \sqrt{K})z^{-2}}{(1 + 1/\sqrt{K}) - 2\cos(\omega_0)z^{-1} + (1 - 1/\sqrt{K})z^{-2}} \tag{15}$$

where

$$= \sinh \frac{\ln(2)}{2} bw \frac{0}{\sin(\omega_0)} \sin(\omega_0)$$

Figs. 4, 5, and 6 show the frequency response, both magnitude and group delay, of a set of equalizer transfer functions with varying boost/cut gain, boost/cut frequency, and bandwidth. Note that when the peak frequency is very high (half Nyquist), there is some distortion in the frequency response symmetry in comparison to an analog equalizer, yet the bandwidth is still very accurate.



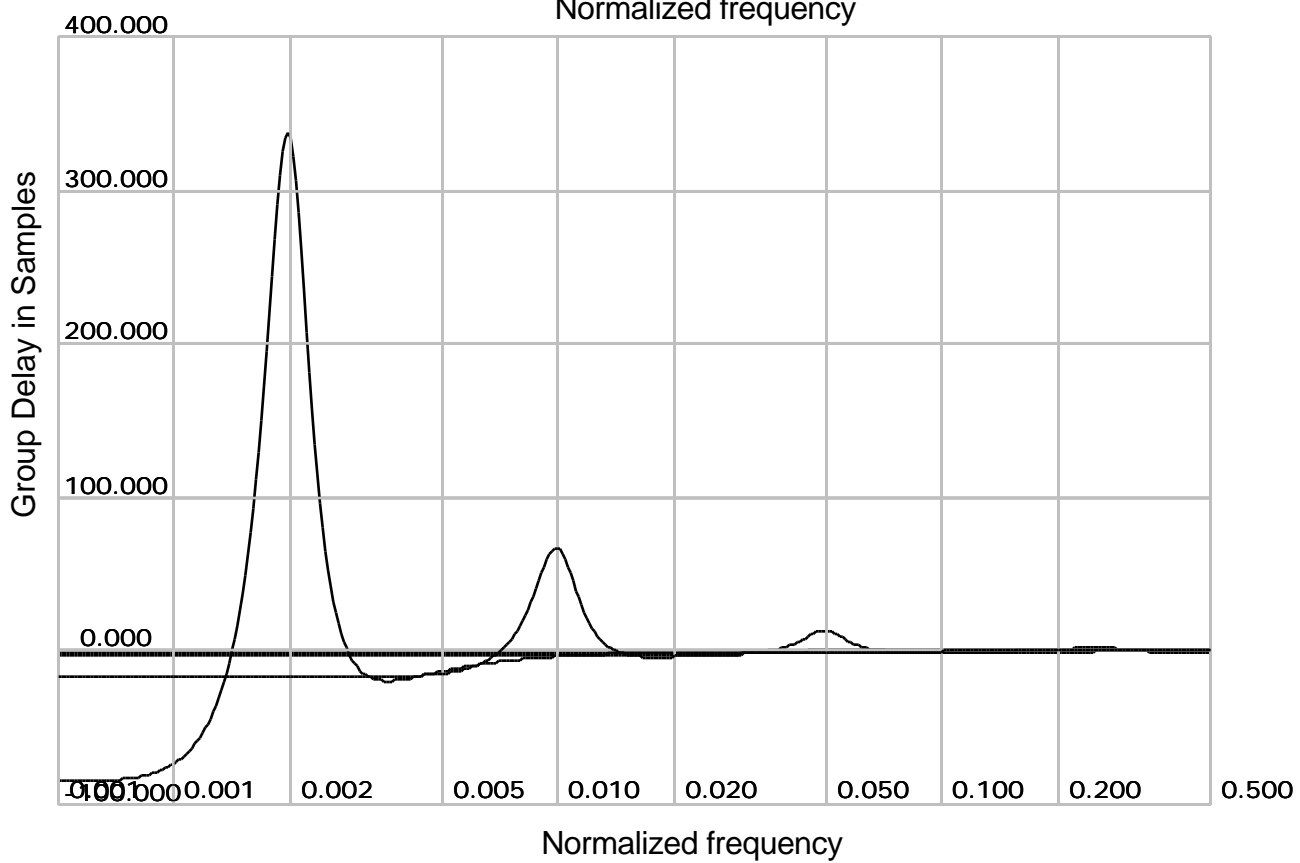
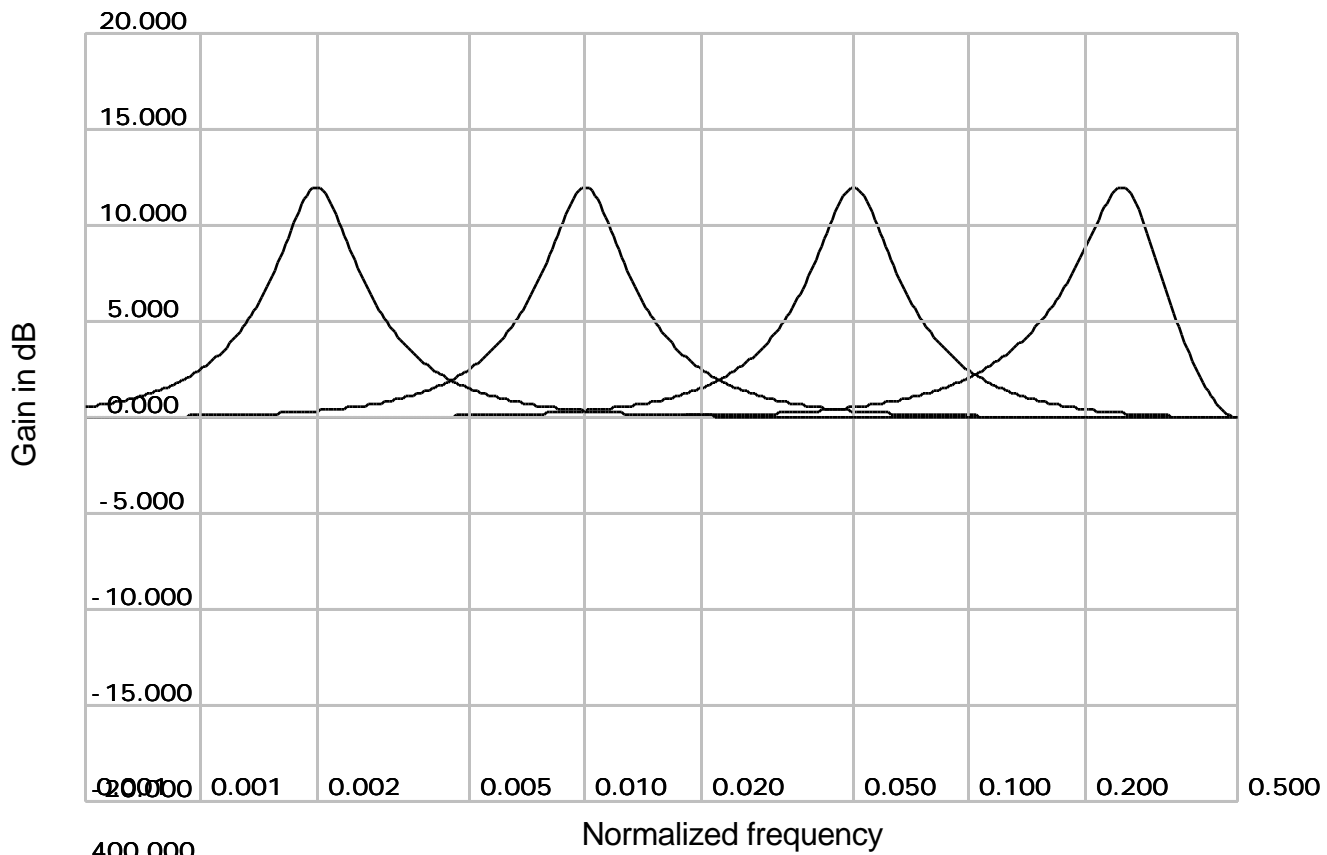

12 dB gain, 1 octave BW, varying peak frequency

Figure 4

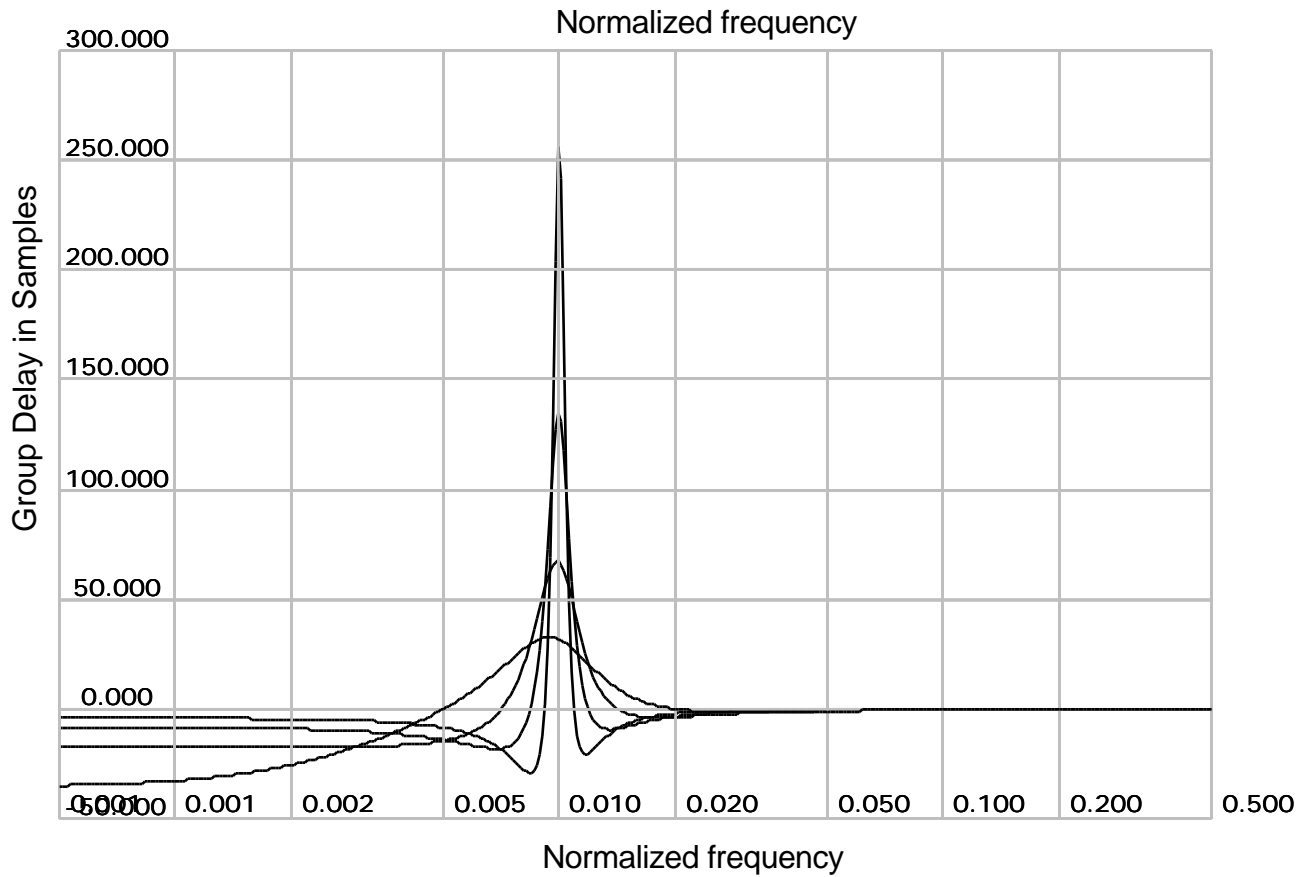
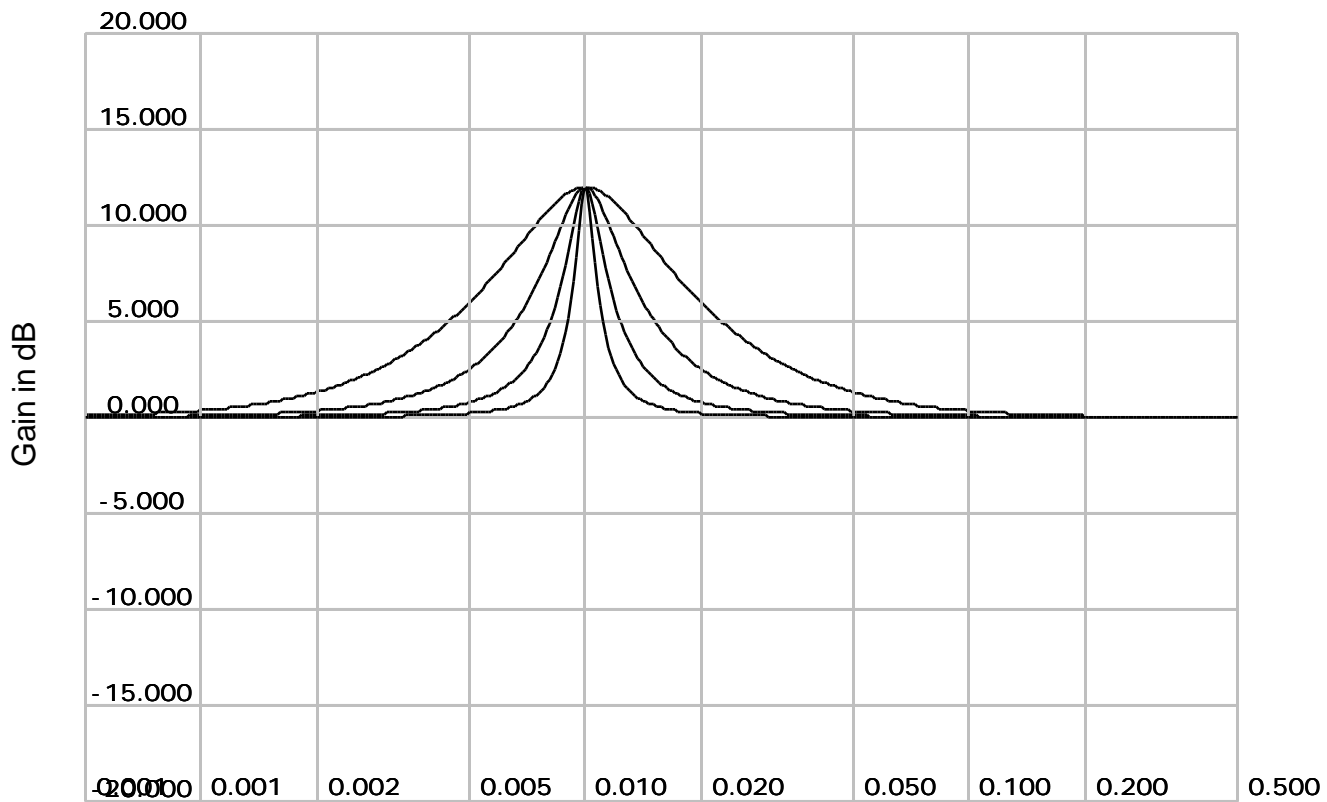

12 dB gain, varying BW, 0.01 peak normalized frequency

Figure 5

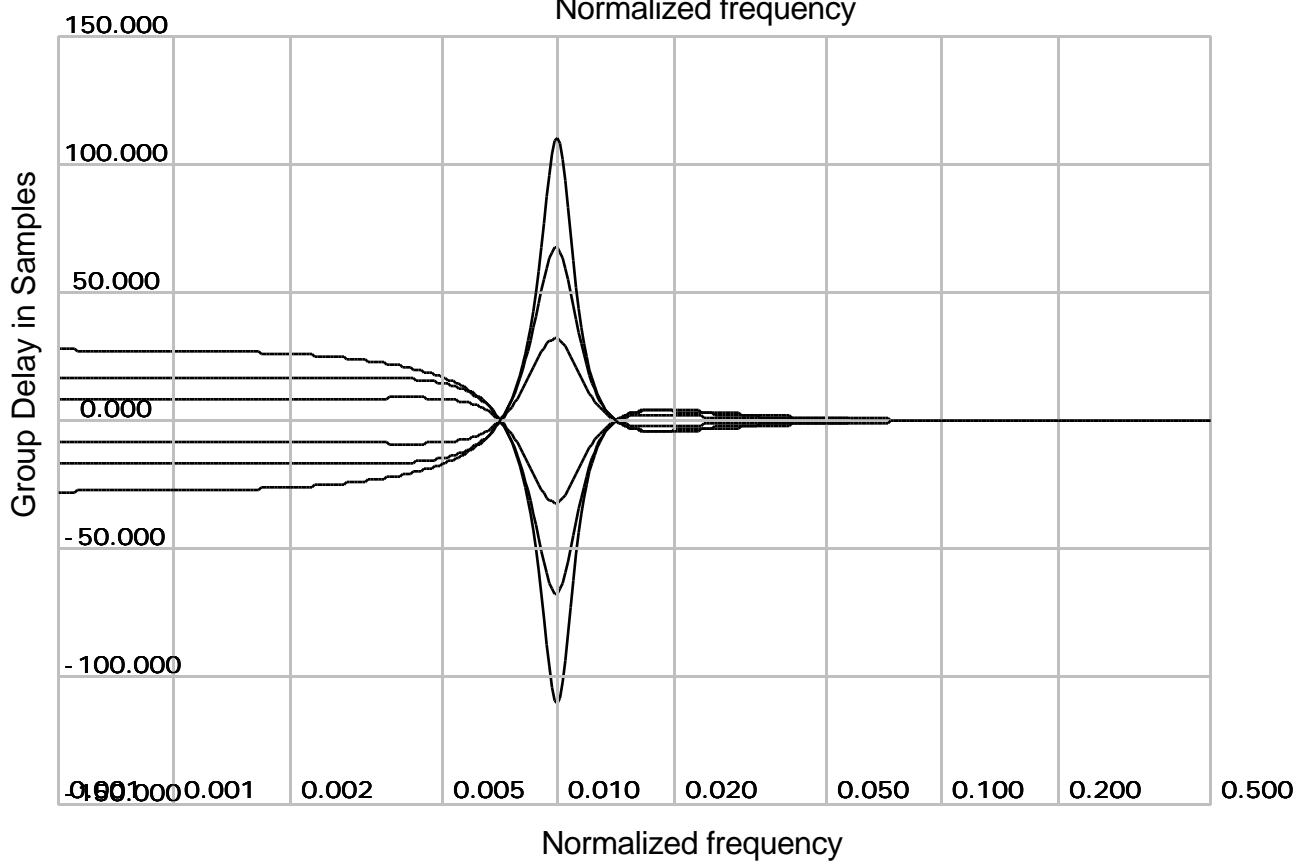
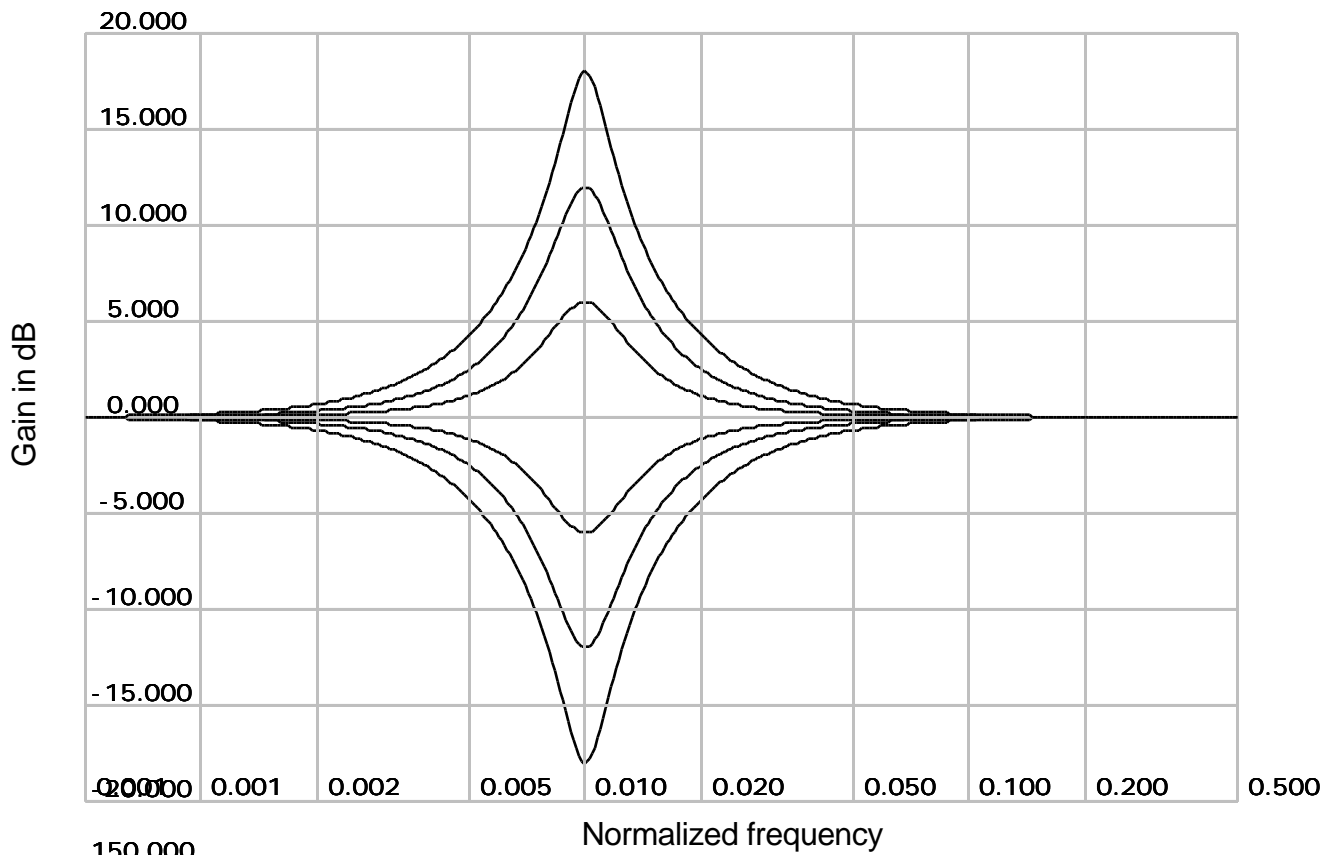

varying gain, 1 octave BW, 0.01 peak normalized frequency

Figure 6

#### 4 COMPARISON OF FILTER COEFFICIENTS

Rearranging eq. (15) to take the form of eq. (1) results in the five biquad coefficients:

$$\begin{aligned}
 b_0 &= \frac{1 + \sqrt{K}}{1 + \sqrt{K}} \\
 b_1 &= a_1 = \frac{-2\cos(\theta_0)}{1 + \sqrt{K}} \\
 b_2 &= \frac{1 - \sqrt{K}}{1 + \sqrt{K}} \\
 a_2 &= \frac{1 - \sqrt{K}}{1 + \sqrt{K}}
 \end{aligned} \tag{16}$$

Because all other design methods referred to here agree on all frequency response constraints save for bandwidth, and since only  $\theta_0$  depends on the bandwidth specification, the other methods must, after sufficient manipulation, take on the same form as eq. (16) with a possible difference in  $\theta_0$ .

The method of Regalia & Mitra [6] and Massie [7] can take the form of eq. (16) if  $\theta_0$  is set to

$$\theta_0 = \sqrt{K} \tan \frac{BW}{2}$$

where  $BW$  is defined in normalized radian frequency difference between the bandedges as defined in the references above.

Moorer's method [2], after considerable simplification, looks like eq. (16) with  $\theta_0$  as

$$\theta_0 = \sqrt{K} \sqrt{\frac{F^2 - 1}{K^2 - F^2}} \tan \frac{BW}{2}$$

where  $BW$  is the normalized radian frequency difference between bandedges having a linear gain  $|H(e^{j\omega})| = F$ . Comparing to the Regalia & Mitra method, one can immediately see that their linear bandedge gain is  $F = \sqrt{\frac{1}{2}} \sqrt{K^2 + 1}$ .

In White's method [3],  $\theta_0$  is

$$= \frac{\sqrt{K}}{P} \tan \frac{BW}{2} \quad P = \begin{cases} \sqrt{K^2 - 2} & K > \sqrt{2} \\ \sqrt{1 - 2K^2} & K < \sqrt{1/2} \\ \text{undefined} & \sqrt{1/2} < K < \sqrt{2} \end{cases}$$

where  $BW$  is the normalized radian frequency difference between bandedges having gain of 3 dB (or -3 dB) for boosts (or cuts) over 3 dB.

## 5 APPLICATION TO NORMALIZED LADDER FORM

The method of Regalia & Mitra [6] and Massie [7] actually doesn't use the direct biquadratic form used above but instead uses an allpass filter (implemented as a two stage 4 multiply normalized ladder form) summed to a feedforward path as shown in Fig. 7. This results in the following transfer function.

$$H(z) = \frac{1}{2} [(1 + K) + (1 - K)A(z)]$$

where  $A(z)$  is an allpass filter, such that when implemented with a lattice or normalized ladder form is

$$A(z) = \frac{k_2 + k_1(1 + k_2)z^{-1} + z^{-2}}{1 + k_1(1 + k_2)z^{-1} + k_2z^{-2}}.$$

One can immediately see that there are only two coefficients to determine ( $K$  is the same as in eq. (5)), however, because of the nature of this architecture, the constraints in eqs. (2), (3), and (5) are automatically satisfied, leaving two constraints (including bandwidth). Substituting the above expression for  $A(z)$  yields

$$H(z) = \frac{\frac{1}{2} [(1 + k_2) + K(1 - k_2)] + k_1(1 + k_2)z^{-1} + \frac{1}{2} [(1 + k_2) - K(1 - k_2)]z^{-2}}{1 + k_1(1 + k_2)z^{-1} + k_2z^{-2}} \quad (17)$$

Comparing eq. (17) to eq. (15) or eqs. (1) and (16) results in

$$k_2 = a_2 = \frac{1 - \sqrt{K}}{1 + \sqrt{K}}$$

$$k_1 = -\cos(\theta)$$

which is consistent with Regalia & Mitra [6] and Massie [7].

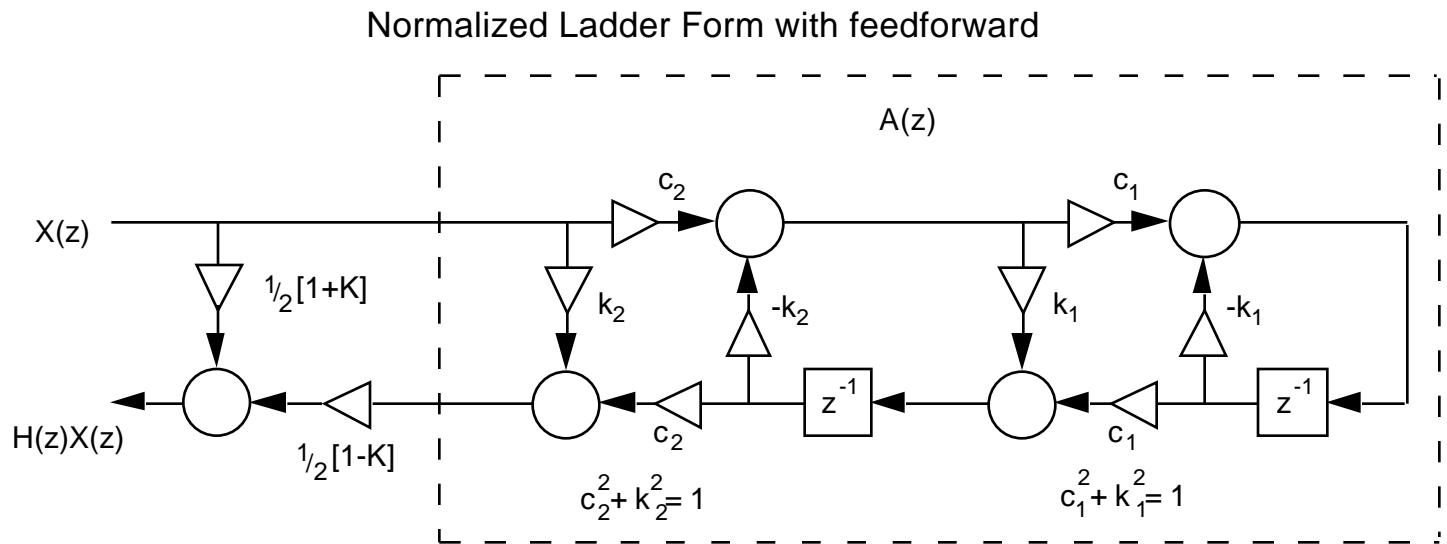

Figure 7

## 6 CONCLUSIONS

If a second order IIR digital filter is used to implement a parametric equalizer, the transfer function expressed as eq. (1) can always have coefficients in the form of eq. (16) with different expressions for given different definitions for bandwidth. Given a common definition for bandwidth, all methods of implementing a second order equalizer must yield identical coefficients for the same architecture, and are therefore equivalent. Choice of architecture need not be a function of frequency response performance and is decoupled from the issue of designing a transfer function that exhibits a desired frequency response.

It would seem that defining bandwidth in an equalizer to be the octave spread between bandedges having half the dB gain of the peak or notch is both meaningful and simple.

## 7 ACKNOWLEDGMENTS

Acknowledgments go to Dana Massie, Andy Moorer, and Eric Richardson.

## 8 REFERENCES

- [1] G. W. McNally, "Digital Audio: Recursive Digital Filtering for High Quality Audio Signals," BBC Research Dept. Rep. 1981/10, 1981.
- [2] J. A. Moorer, "The Manifold Joys of Conformal Mapping: Applications to Digital Filtering in the Studio," *J. Audio Eng. Soc.*, vol. 31, pp. 826-841 (1983 Nov.).
- [3] S. A. White, "Design of a Digital Biquadratic Peaking or Notch Filter for Digital Audio Equalization," *J. Audio Eng. Soc.*, vol. 34, pp. 479-483 (1986 June).
- [4] S. K. Mitra, K. Hirano, and S. Nishimura, "Design of Digital Bandpass/Bandstop Filters with Independent Tuning Characteristics", *Frequenz*, Vol. 44, pp. 117-121, 1990.
- [5] f. j. harris and E. Brooking, "A Versatile Parametric Filter using an Imbedded All-Pass Sub-Filter to Independently Adjust Bandwidth, Center Frequency, and Boost or Cut," presented at the 95th Convention of the AES (1993 Oct.), preprint 3757.
- [6] P. A. Regalia and S. K. Mitra, "Tunable Digital Frequency Response Equalization Filters," *IEEE Trans. Acoust., Speech, Signal Process.*, vol. ASSP-35 (1987 Jan.).
- [7] D. C. Massie, "An Engineering Study of the Four-Multiply Normalized Ladder Filter," *J. Audio Eng. Soc.*, vol. 41, pp. 564-582 (1986 July/Aug.).